



韦克斯科技（北京）有限公司

WIX TECHNOLOGY BEIJING CO., LTD

WIX-easyPRO4 Mini Easy Vertical Electrophoresis Cell

Instruction Manual



WIX TECHNOLOGY BEIJING CO.,LTD

Add: No. 10 Building Dongliantongchuang Sci-Tech Park, No.738 Changliu Road Machikou
Town Changping District Beijing People's Republic of China

Email: sales3@wixcompany.com Web: <http://www.wixcompany.com/>



Content

Chapter 1 Generalization	4
1.1 Brief introduction	4
1.2 Component.....	4
Chapter 2 Installation and basic operation	6
2.1 Preparing gel plate.....	6
2.2 Installation of electrophoresis module and adding sample....	8
Chapter 3 Trouble shooting.....	1 1
Chapter 4 Quality guarantee	1 3



韦克斯科技（北京）有限公司

WIX TECHNOLOGY BEIJING CO., LTD

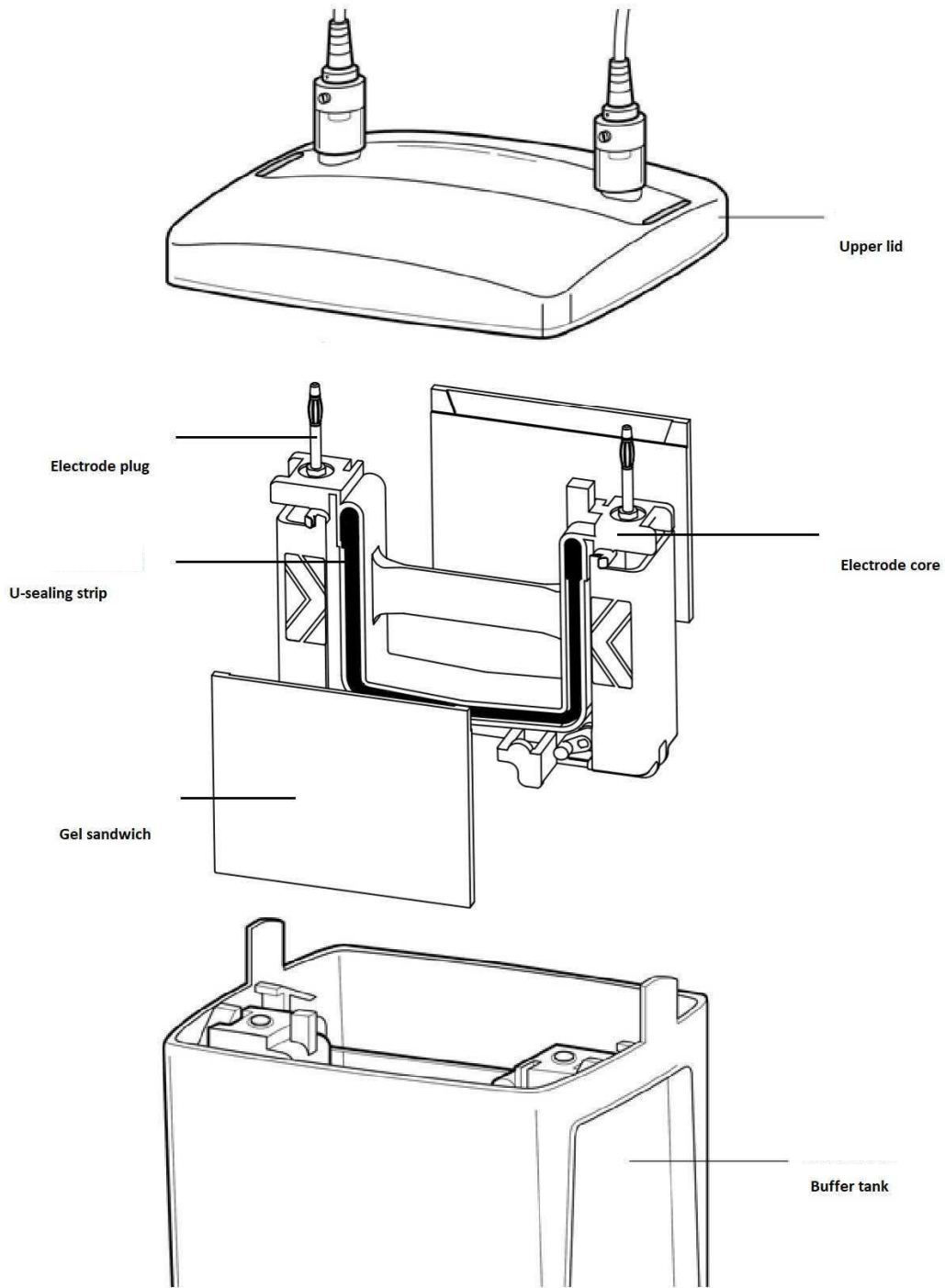

Add: No. 10 Building Dongliantongchuang Sci-Tech Park, No.738 Changliu Road Machikou
Town Changping District Beijing People's Republic of China

Email: sales3@wixcompany.com Web: <http://www.wixcompany.com/>



Chapter 1 Generalization

1.1 Brief introduction

WIX-easyPRO Vertical Electrophoresis Cell is used to run pre-casting gel and hand-casting gel, at most 4 pieces of gels are available simultaneously. It is compatible with 1-D and 2-D electrophoresis application. The gel-making frame and glass plate with fastening side strip make the activity of hand-casting gel simple and avoid the leakage.

1.2 Component

In order to achieve best performance, please read the instruction manual carefully and operate the instrument strictly according to the instruction manual.

Glass plate with fastening side stripe: It is the relatively high glass plate with fastening side stripe. There are 3 kinds of glass plate with the thickness of 0.75mm, 1.0mm, 1.5mm respectively.

Short glass plate: It is the relatively short glass plate and combined with glass plate to form the gel sandwich clamp.

Gel-casting frame: It is put on the desk and align the short glass plate and glass plate with fastening side strip, and make sure to form the gel sandwich clamp.

Components of gel clamp: 1 piece of gel casting frame, a piece of glass plate with fastening side stripe and a piece of short glass plate.

Gel base: Pressure leverage seal the components of gel to the gel casing pad to avoid the leakage of gel.

Gel sandwich: It consists of short glass plate and glass plate with side strip as well as polymer gel.

Replacement plate for single gel: Transparent mound pressing baffle, it is used to make 1 piece of gel or 3 pieces of gels.

Electrophoresis core: It is used to hold the gel sandwich and supply the U-sealing strip and upper and lower electrode as well as connecting plug. Anode is marked by red while the cathode is marked by black.

1.3 Technical specification

Buffer tank and upper lid: The buffer tank and the upper lid are closed to make sure the electrophoresis is conducted smoothly. The power is off when the upper lid is opened. The tank and upper lid are compatible with other electrophoresis module, such as the electrophoresis transfer, 2-D single direction electrophoresis and electrophoresis elution etc.

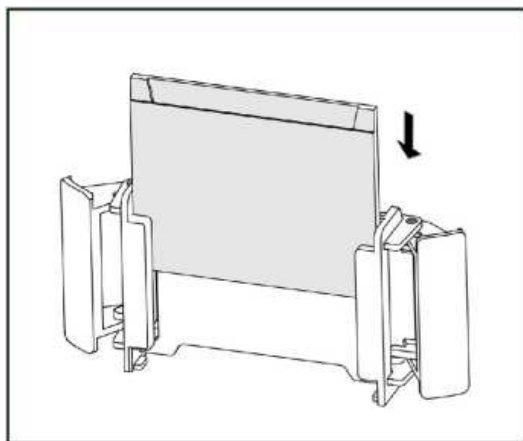

Figure 1: WIX-easyPRO electrophoresis installation

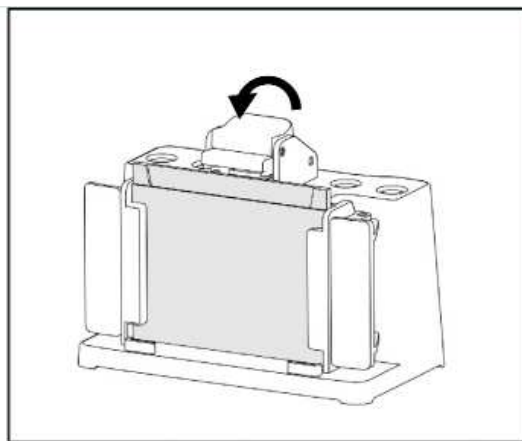

Figure 2: Installation of gel frame and gel-casting stand

Maximum volume of sample

Hole quantity	Width of hole	Width of		
		0.75 mm	1.0 mm	1.5 mm
5	12.7 mm	70 μ l	105 μ l	160 μ l
9	5.08 mm	33 μ l	44 μ l	66 μ l
10	5.08 mm	33 μ l	44 μ l	66 μ l
15	3.35 mm	20 μ l	26 μ l	40 μ l
IPG	6.2 mm	----	420 μ l	730 μ l
Prep/2-D				
Reference well	3.1 mm	13 μ l	17 μ l	30 μ l
Sample well	71.7 mm	310 μ l	400 μ l	680 μ l

Compatibility of chemical reagent:

All the components of WIX-easyPRO electrophoresis cell should be kept clear of acetone and ethyl alcohol. The damage caused by using the organic reagent is not covered by the guarantee policy.

The comb of WIX-easyPRO electrophoresis cell should be kept clear of 100% TEMED, whose structure will be damaged by long time friction of TEMED.

1.4 Safety instruction

The power is off when the upper lid is opened, never try to operate the electrophoresis when there is no upper lid.



Note: The safety standard is applied to the WIX product from design stage to production stage, and it would be safe in case of proper and right operation. Please do not improve or mend it by any means.

Chapter 2 Installation and basic operation

2.1 Preparing gel plate

Hand casting gel

1. Note to installation of glass plate clamp and gel casting frame

a. Put the gel casting frame vertically on the horizontal desk and let the door of gel casting frame open.

b. Choose the glass plate with side strip according to the thickness of gel and put the shore glass plate above (Please refer to the figure 3a).

c. Keep the marked tip of glass plate with side strip up, slide 2 pieces of glass plates into the gel casting frame, make the face of shore glass forward (Please refer to the figure 3b).

Note: Keep the 2 pieces of glass plates on the same level and right direction of marker. The leakage occurs in case of wrong direction of glass plate and non aligning.

d. Close the hinge of gel casting frame if the glass plate is in the right position, clamp the glass plate tightly in gel casting frame (Please refer to figure 3c). Check the bottom of glass plate is level.

e. Keep the hinge of gel casting frame outward and put the gel casting frame on the gray gel gasket of gel base, the put the spring leverage on the glass plate with side strip (Please refer to figure 3d).

f. Repeat step a-e to make another gel plate.

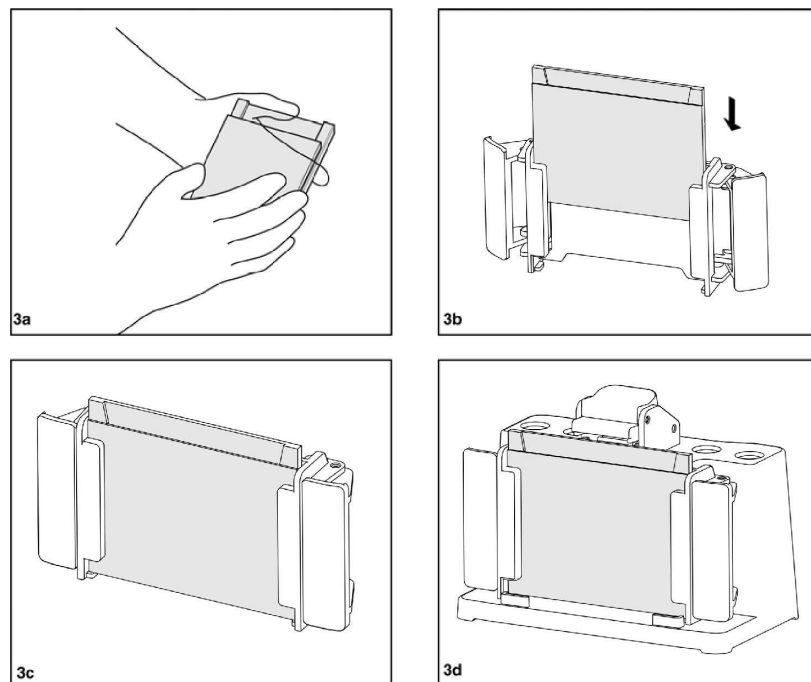

Figure 3: Installation of gel casting frame and gel base.



Gel casting

a. Non continued polyacrylamide gel

1. Put the comb into the gel clamp completely and mark the part 1 cm below the lower end of tooth. The mark indicates the height of separated gel.
2. Blend all the reagent except APS and TEMED to make gel single solution (Please refer to gel list of chapter 4), vacuum degassing for more than 15 minutes.
3. Put APS and TEMED in single solution after being vacuum degassed, and use the pipette or sample adding pipette to inject the solution between glass plate until reach the marker. Keep stable injection in order to avoid the blend with air.
4. Cover the surface of solution by water or tert-amyl alcohol (2- methyl, 2- butanol). Note: Please inject the water slowly and stably in order to avoid blend with air.
5. Leave the gel from 45 minutes to 60 minutes until it is of polymerization. Cleanse the surface of gel completely by double distilled water. Do not let the matters of alcohol kind stay on the gel more than 1 hour in order to avoid the dehydration of upper part of gel.
Note: Such separated gel can be store in room temperature overnight. Add 5 ml of 1.5M Tri-HCl with ratio of 1 to 4 and buffer with pH8.8 (Laemmli system) to the separated gel to be dried. In case of other buffer, please add 5 ml of 1 fold diluted solution.
6. Prepare spacer gel single solution, blend all the reagents except APS and TEMED, vacuum degassing for more than 15 minutes.
7. Use the filter paper to dry the surface of separated gel before injecting spacer gel.
8. Add APS and TEMED in the degassed spacer gel single solution and inject the solution until it reaches the level the glass plate.
9. Insert comb and make sure that the back of comb and the glass plate are on the same level.
10. Leave the gel from 45 minutes to 60 minutes until it is of polymerization.
11. Take out the comb slightly and cleanse the surface of gel by distilled water and buffer.
12. Cleanse the used gel clamp frame and gel casting frame by distilled water and ion-removing water.

b. Continued polyacrylamide gel

1. Blend all the reagent except APS and TEMED to make gel single solution (Please refer to gel list of chapter 4), vacuum degassing for more than 15 minutes.
2. Put APS and TEMED in single solution after being vacuum degassed, and inject the solution until it reaches the level the glass plate.
3. Insert comb and make sure that the back of comb and the glass plate are on the same level.
4. Leave the gel from 45 minutes to 60 minutes until it is of polymerization.
5. Take out the comb slightly and cleanse the surface of gel by distilled water and buffer.



And cleanse the used gel clamp frame and gel casting frame by distilled water and ion-removing water.

2.2 Installation of electrophoresis module and adding sample

Clean and dry WIX-easyPRO electrophoresis buffer tank.

Electrophoresis module (Electrophoresis core can only be used for 1 piece gel or 2 pieces of gels, the shared module should be used in case of 3 pieces of gels or 4 pieces of gels.

1. Installation

Note: If only run 2 pieces of gels, please use electrode head electrophoresis core. If only run 4 pieces of gels, please use the electrode head electrophoresis core and mushroom head electrophoresis core, each module for 2 pieces of gels.

- a. Put the opened gel-casting frame on the clean and horizontal surface of desk (Please refer to the figure 4a).
- b. Adjust the short glass plate inwardly, put the first gel sandwich on the gel supporter, put the module of gel supporter on both two sides of bottom of module, each side with two, in case of which, there is a 30 degree angle between the middle side of gel plate. Be careful to put the first gel and keep balance, then put the second gel on the other side of gel supporter. There are totally 2 pieces of gel slant from the center (Please refer to the figure 4b).
- c. Note: Be sure to adjust the short glass plate inwardly and then put the gel on the two sides of gel clamping frame. The gel clamping frame requires 2 pieces of gels to form the functional module. In case of running odd number of gel (1 piece of gel or 3 pieces of gels), please use single gel plate (Please refer to figure 4b).
- d. Push 2 pieces of gel plates slightly to the center and close to red gel band, to make sure that the short glass plate is under the concaved tank of red gel gasket.
- e. Compress the gel plate tightly by one hand, while close the red gel clamp frame by another hand and make it in the best position. Or hold the whole unit and stabilize the gel plate and close gel clamp frame on both two sides in order to make it be locked in the right position (Please refer to the figure 4c). The gel clamp frame pushes the gel plate and make the concaved tank of short glass plate and concaved tank of red gel gasket matched together tightly in order to avoid the leakage of liquid (Be sure the the short glass plate is under the bottom of concaved tank of red gel gasket). Thus, use the buffer to cleanse the sample and start to add the sample (Please refer to the figure 4b).

Important note: Never try to close the gel clamp frame when the gel plate is not under the bottom of concaved tank of red gel gasket. In order to avoid the movement of gel plate in the



process of being locked, please use single hand to compress the gel plate on the two sides of gel clamp frame stably and evenly.

Note: Please do not put mushroom head electrophoresis core in the electrophoresis cell, otherwise the surplus heat is generated which affects the result of electrophoresis separation.

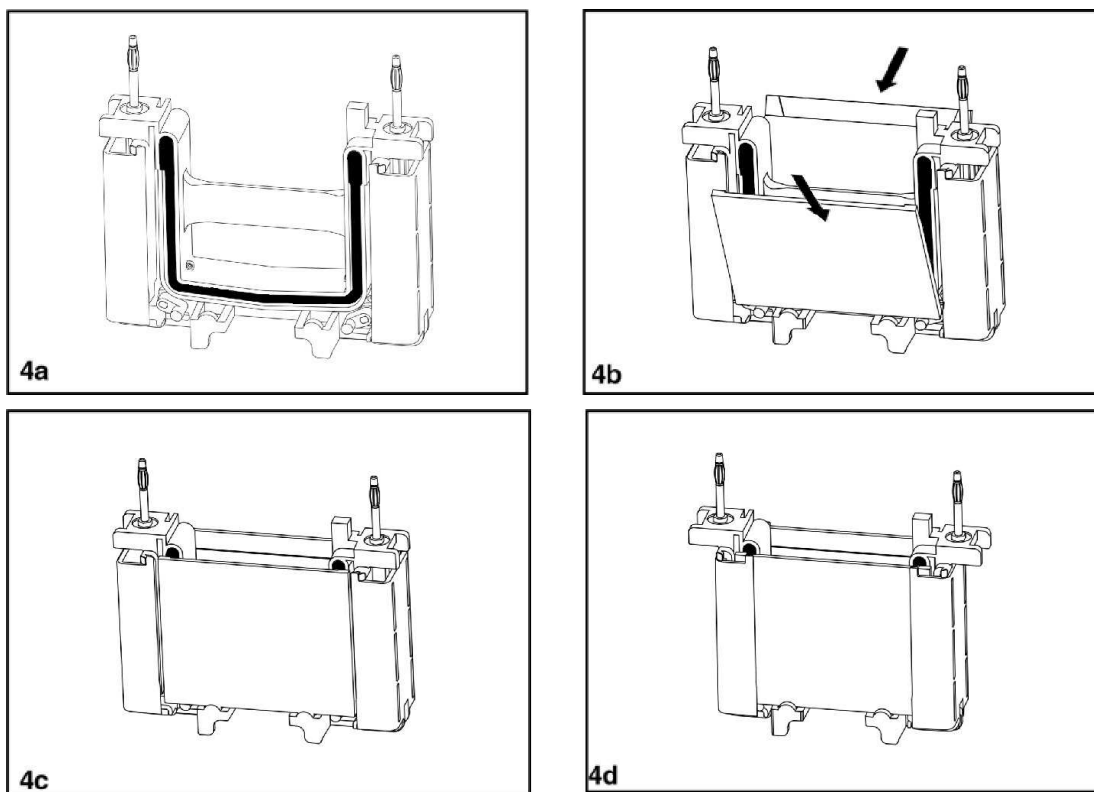

Figure 4: Installation of WIX-easyPRO electrophoresis module.

2. Sample adding

a. Inject the buffer into the tank, from the outside of outer tank and follow lower part of glass plate, just flood the short glass plate slightly.

b. Add the sample before or after the electrophoresis core is put in the electrophoresis cell, both of two methods are available to obtain the satisfied result.

c. Add the sample into the hole by syringe and sample adding pipette.

Note: Make the sample fall onto the bottom of hole slowly and evenly. Be sure not to puncture the bottom.

Note: Anode and cathode should be flooded by the buffer and on the same level.

3. Put the electrophoresis module in the buffer tank.

Note: The volume requires, 2 pieces of gels with 700ml, 4 pieces of gels with 1000ml.

There are two places of buffer tank for two module: Electrophoresis core is second and the mushroom head electrophoresis core is first.



- a. Put the WIX-easyPRO buffer on the smooth desk, make the front side (The side indicating the words of 2 gels and 4 gels) forward. If the direction is correct, the red mark of edge of tank should be on the right side and the black left.
- b. If running 2 pieces of gels, please use the electrophoresis core with plug. Put it on the back and make the red (+) corresponding to the red mark on the right side of tank.
- c. If running 4 pieces of gels, please use not only the electrophoresis core with plug but also the mushroom head electrophoresis core that should put in the front. Make the red (+) of the two corresponding to the red mark on the right side of tank. Note: The wrong direction and position will make the upper lid impossible to be closed.
- d. Put the buffer into the tank until reach the marker.

4. WIX-easyPRO installation of buffer tank

Put the upper lid on the buffer tank, and make sure the plug and socket match to obtain the right location, the protruded part of upper lid can help avoid the error. Note: The two protruded parts of buffer tank should go through the slot of upper lid in order to make it open and close smoothly. At this time, please compress the upper lid continuously with thumb until it is done.

5. Power condition

- a. Insert the plug into the socket correctly.
- b. Power on the WIX-easyPRO, the constant voltage is 200V is recommended to SDS-PAGE and most of native PAGE. 200V voltage can be used to run 2 pieces of gels and 4 pieces of gels. The customer choose the voltage according to the real situation. SDS-PAGE needs around 35 minutes under the voltage of 200V.

6. Extract gel

- a. Power off and take out the plug when the electrophoresis is done.
- b. Open the upper lid, take out the electrophoresis core carefully, and remove the buffer. Please pour out the buffer before open the clamp.
- c. Take out the gel plate.
- d. Separate the two glass plates carefully and take out the gel.
- e. Put the gel downward and immerse the gel and glass plate in the buffer and make them separated.
- f. Cleanse the WIX-easyPRO electrophoresis core and buffer tank by the ion-removing distilled water.



Chapter 3 Trouble shooting

Problem	Cause	Solution
Smile effect – band pattern curves upward at both sides of the gel	<ul style="list-style-type: none"> ◆ Center of the gel running hotter than either end ◆ Power conditions excessive 	<ul style="list-style-type: none"> ◆ Buffer not mixed well or buffer in upper chamber too concentrated. Remake buffer, ensuring thorough mixing, especially when diluting 5x or 10x stock. ◆ Decrease the power setting from 200 V to 150 V or fill lower chamber to within 1 cm of top of short plate.
Vertical streaking of protein	<ul style="list-style-type: none"> ◆ Sample overloaded ◆ Sample precipitation 	<ul style="list-style-type: none"> ◆ Dilute sample, selectively remove predominant protein in sample, or reduce the voltage about 25% to minimize streaking. ◆ Centrifuge sample before addition of SDS sample buffer, or decrease %T of the gel* ◆ The ratio of SDS to protein should be enough to coat each protein molecule with SDS, generally 1.4:1. ◆ It may require more SDS for some membrane protein samples.
Lateral band spreading	<ul style="list-style-type: none"> ◆ Diffusion of the wells prior to turning on the current. ◆ Ionic strength of the sample lower than that of the gel. 	<ul style="list-style-type: none"> ◆ Minimize the time between sample application and turning on the power start-up. ◆ Use same buffer in sample as in the gel or the stacking gel.
Skewed or distorted band	<ul style="list-style-type: none"> ◆ Poor polymerization around wells ◆ Salts in sample ◆ Uneven gel interface 	<ul style="list-style-type: none"> ◆ Degas stacking gel solution completely prior to casting; +C2:C5 increase ammonium persulfate and TEMED concentrations by 25%, for stacking gel or low %T, leave APS the same and double the TEMED concentration. ◆ Remove the salts by dialysis, desalting, column, etc. ◆ Decrease the polymerization rate. ◆ Overlay gels very carefully.
Lanes constricted at the bottom of the gel	<ul style="list-style-type: none"> ◆ Ionic strength of sample higher than the surrounding gel 	<ul style="list-style-type: none"> ◆ Desalt sample and neighboring samples.



Run taking unusually long	<ul style="list-style-type: none"> ◆ Running buffer too concentrated ◆ Excessive salt in sample 	<ul style="list-style-type: none"> ◆ Check buffer protocol, dilute if necessary ◆ Desalt sample
Run too fast	<ul style="list-style-type: none"> ◆ Running or reservoir buffer too dilute ◆ Voltage too high 	<ul style="list-style-type: none"> ◆ Check buffer protocol, dilute if necessary ◆ Decrease voltage by 25–58%
Doublets observed where single protein species is expected (SDS-PAGE)	<ul style="list-style-type: none"> ◆ A portion of the protein may have been re-oxidized during the run or may not have been fully reduced prior to the run 	<ul style="list-style-type: none"> ◆ Prepare fresh sample buffer solution if over 30 days old ◆ Increase concentration in the sample buffer ◆ Substitute DTT for BME
Fewer bands than expected and one heavy band at the dry front	<ul style="list-style-type: none"> ◆ Protein(s) migrating at the dye front ◆ Protein degradation 	<ul style="list-style-type: none"> ◆ Increase the %T of the resolving gel ◆ Use protease inhibitors, e.g., PMSF, etc
Fewer bands than expected and one heavy band at the dry front	<ul style="list-style-type: none"> ◆ Protein(s) migrating at the dye front ◆ Protein degradation 	<ul style="list-style-type: none"> ◆ Increase the %T of the resolving gel* ◆ Use protease inhibitors, e.g., PMSF, etc.
Upper buffer chamber leaks	<ul style="list-style-type: none"> ◆ Upper buffer chamber overfilled ◆ Improper assembly 	<ul style="list-style-type: none"> ◆ Keep buffer level below the top of the spacer plate ◆ Be sure U-shaped electrode core gasket is clean, free of cuts, and lubricated with buffer ◆ Be sure short plate is under the notch on the gasket, not on top of it
Leaking during hand casting	<ul style="list-style-type: none"> ◆ Chipped glass plates ◆ Spacer plate and short plate not level ◆ Casting stand gasket is dirty, flawed, or worn out. 	<ul style="list-style-type: none"> ◆ Ensure glass plates are free of flaws ◆ Ensure plates are aligned correctly ◆ Wash the gasket if it is dirty, replace casting stand gaskets if flawed or worn out
Poor end well formation	<ul style="list-style-type: none"> ◆ Incorrect catalyst formation ◆ Monomer solution not degassed ◆ Oxygen inhibits polymerization 	<ul style="list-style-type: none"> ◆ Prepare fresh catalyst solution, or increase the catalyst concentration of the stacking gel to 0.06% APS and 0.12% TEMED ◆ Degas monomer solution immediately prior to casting the stacking gel
Webbing/excess acrylamide behind the comb	<ul style="list-style-type: none"> ◆ Incorrect catalyst concentration 	<ul style="list-style-type: none"> ◆ Prepare fresh catalyst solution, or increase the catalyst concentration of the stacking gel to 0.06% APS and 0.12% TEMED



The pressure cams on the casting frame are difficult to close or make noise when closed

◆ Powder residue has built up at the pivot of the pressure cams

◆ Rinse or wipe off the powder residue before each use

Chapter 4 Quality guarantee

- (1) The warranty is 2 years since the date of sales.
- (2) The warranty excludes the following situations otherwise it is charged/
 - a. No presentation of warranty card and invoice.
 - b. The invoice is revised.
 - c. Improper operation or accident factors.
 - d. The damage is caused by the user's repair.
 - e. Out of the warranty, the instrument is still in usage after repair.

WIX TECHNOLOGY (BEIJING) CO.,LTD

Tel: +86 010-89797600

E-mail: sales3@wixcompany.com

Website: <http://www.wixcompany.com/>

Add: No. 10 Building Dongliantongchuang Sci-Tech Park, No.738 Changliu Road Machikou

Town Changping District Beijing P.R.C.

Postcode: 102202